

BLOCK 9 - BUILDING ELEVATION  
 1/32" = 1'-0"

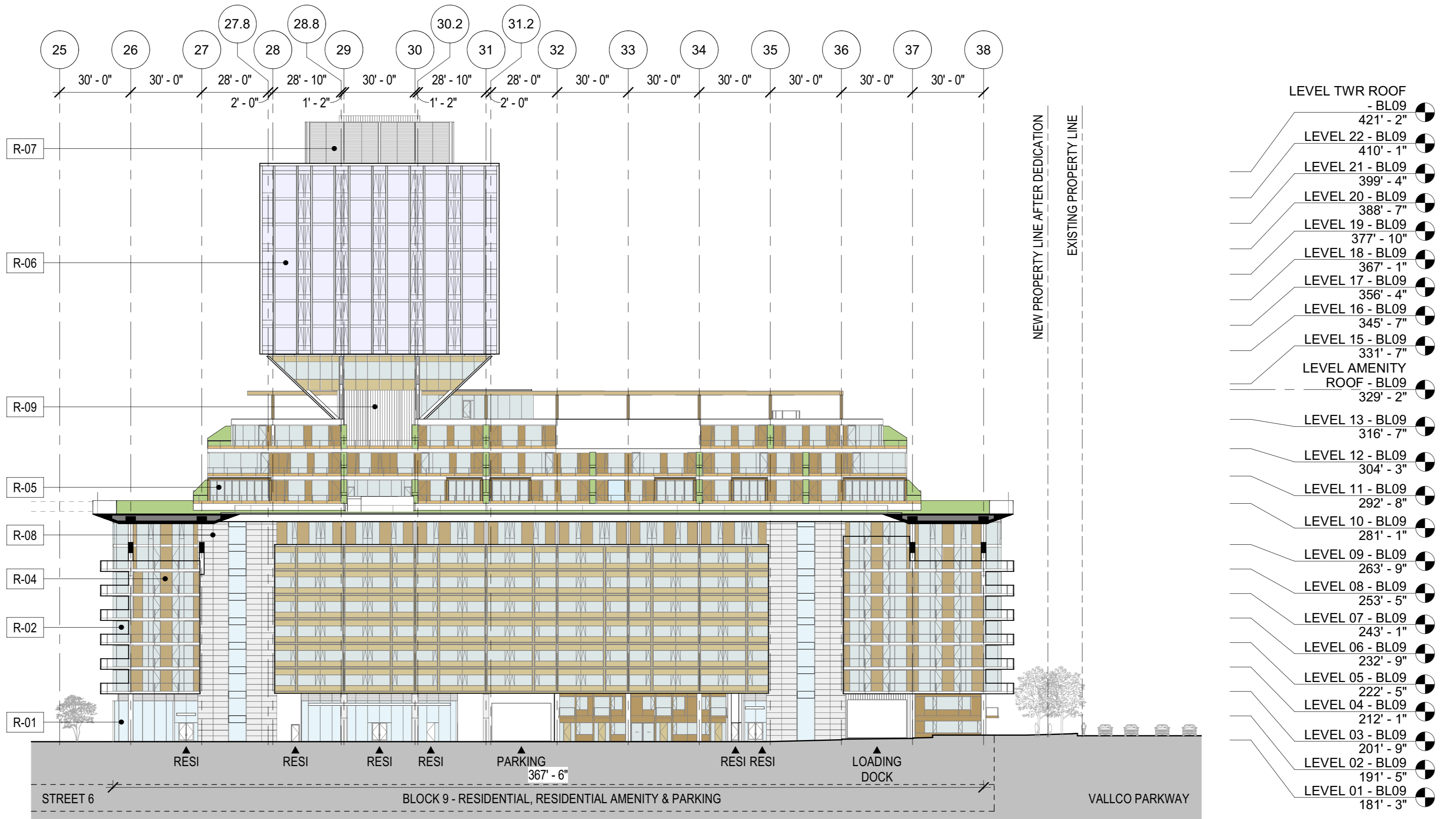

BLOCK 9 - BUILDING ELEVATION  
 1/32" = 1'-0"

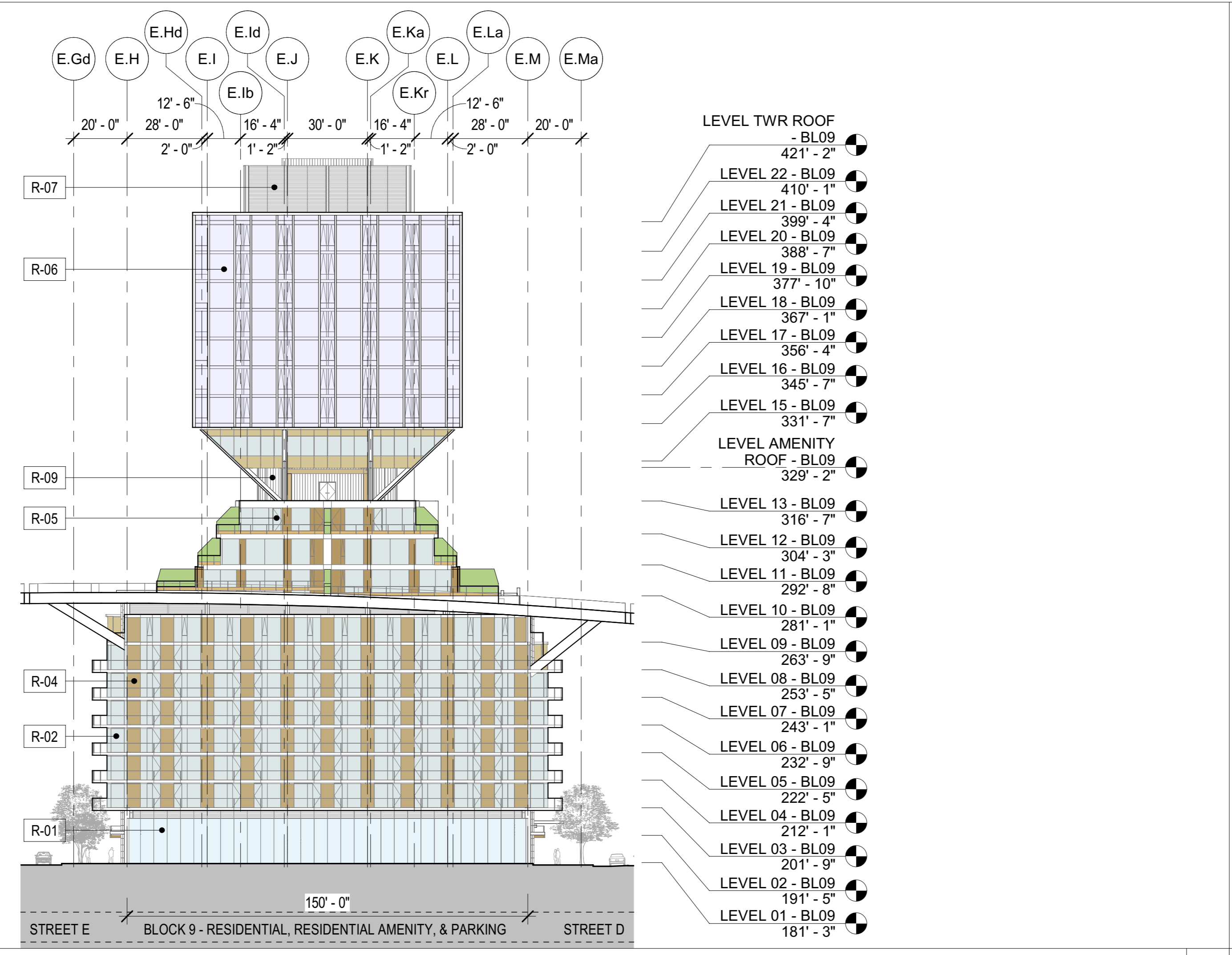

**WALL FINISH LEGEND - OFFICE BLOCKS**

- O-01 STOREFRONT
- O-02 TRANSPARENT PANEL
- O-03 OPAQUE PANEL
- O-04 ARCHITECTURAL LOUVERS (MEP SCREENING)

REFER TO P-0862 FOR FURTHER INFORMATION

**WALL FINISH LEGEND - RESIDENTIAL BLOCKS**

- R-01 STOREFRONT
- R-02 TRANSPARENT PANEL
- R-03 SLIDING SCREENS
- R-04 "WOOD" LOOK OPAQUE PANEL
- R-05 SLIDING, SWING, AND FOLDING DOORS
- R-06 WINDOW WALL
- R-07 ARCHITECTURAL LOUVERS (MEP SCREENING)
- R-08 STONE CLADDING
- R-09 METAL PANEL CLADDING

REFER TO P-0861 FOR FURTHER INFORMATION

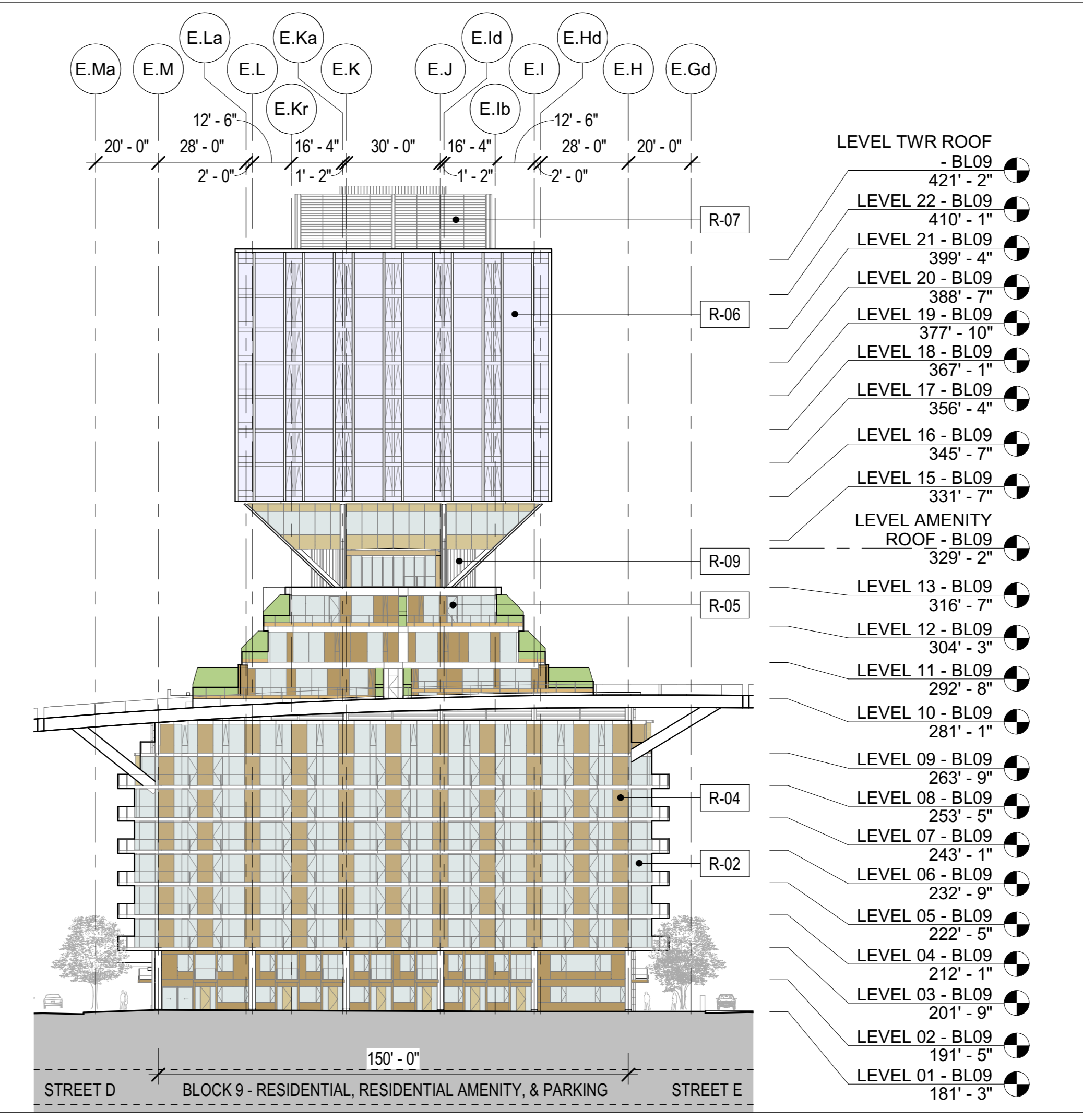

BLOCK 9 - BUILDING ELEVATION  
 1/32" = 1'-0"

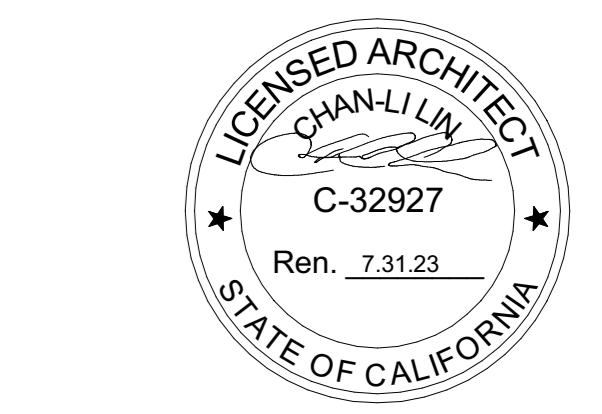

**NOT FOR CONSTRUCTION**

STAMP SIGNATURE

DISCLAIMER  
 THE ARCHITECT/ENGINEER SHALL HAVE NO RESPONSIBILITY FOR ANY LIABILITY, LOSS, COST, DAMAGE OR EXPENSE ARISING FROM OR RELATING TO ANY USE OF THIS DOCUMENT FOR ANY PURPOSE OTHER THAN ITS INTENDED PURPOSE ON THIS PROJECT. THIS DOCUMENT IS TO BE CONSIDERED IN CONJUNCTION WITH ALL RELATED DOCUMENTATION. ANY DISCREPANCIES IDENTIFIED IN THIS DOCUMENT MUST BE REPORTED IMMEDIATELY TO THE ARCHITECT BEFORE PROCEEDING. CONTRACTORS MUST VERIFY ALL DIMENSIONS PRIOR TO PROCEEDING WITH ANY WORK. ONLY FIGURED DIMENSIONS ARE TO BE USED FOR VERIFICATION.

**SB-35 MODIFICATION APPLICATION**

REV	DESCRIPTION	DATE
REV-0	SB-35 APPLICATION - REVISION	08/02/2018
REV-1	SB-35 APPLICATION - CONFORM SET	09/15/2018
REV-2	SB-35 MODIFICATION APPLICATION	03/23/2022

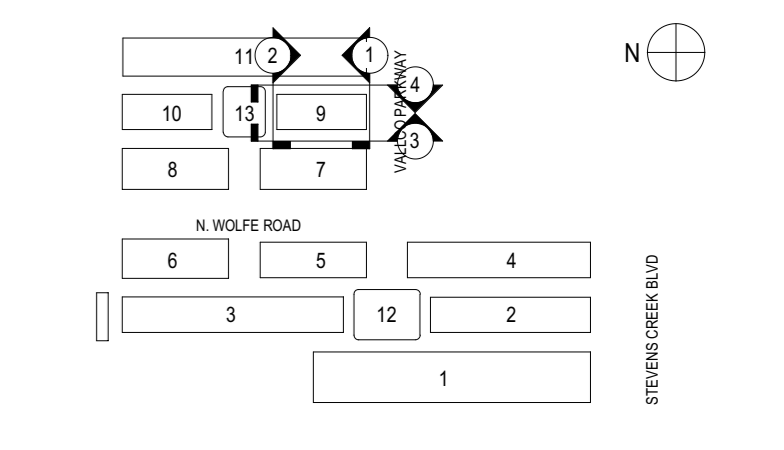

KEY PLAN AND NORTH ARROW

ARCHITECTS PROJECT NUMBER 708.012

IF THIS DRAWING IS NOT 36"x48" IT IS A REDUCED PRINT. REFER TO GRAPHIC SCALE

SCALE: AS NOTED

**ENLARGED BUILDING ELEVATIONS - BLOCK 9**

SHEET TITLE

**P-0825.09**