

OWNER - VALLCO PROPERTY OWNER LLC
 2600 EL CAMINO REAL, SUITE 410, PALO ALTO, CA 94306
 T. 650-344-1500

ARCHITECTURE - RAFAEL VINOLY ARCHITECTS
 375 PEARL STREET, 31ST FLOOR, NEW YORK, NY 10038
 T. 212-929-0500

ARCHITECTURE - RAFAEL VINOLY ARCHITECTS
 10123 N. WOLFE ROAD, CUPERTINO, CA 95014
 T. 408-627-7090

LANDSCAPE ARCHITECTURE - OLIN PARTNERSHIP LTD.
 1917 JOHN F. KENNEDY BLVD, SUITE 1800, PHILADELPHIA, PA 19103
 T. 214-440-0030

CIVIL - SANDIS CIVIL ENGINEERS SURVEYORS PLANNERS, INC.
 1700 S. WINCHESTER BLVD, SUITE 200, CAMPBELL, CA 95008
 T. 408-638-0900

TRAFFIC - KIMLEY-HORN AND ASSOCIATES, INC.
 1001 W. SAN FERNANDO STREET, SUITE 230, SAN JOSE, CA 95113
 T. 669-800-4130

LIGHTING DESIGN - ONE LUX STUDIO
 150 WEST 29TH STREET, 10TH FLOOR, NEW YORK, NY 10001
 T. 212-201-8750

SIGNAGE & WAYFINDING - EXIT DESIGN
 725 N. 4TH STREET, PHILADELPHIA, PA 19123
 T. 215-581-1550

PARKING ENGINEERING - WATRY DESIGN, INC.
 2099 GATEWAY PLACE, SUITE 500, SAN JOSE, CA 95110
 T. 408-392-7050

FOOD SERVICE, WASTE MANAGEMENT & LOGISTICS - CINI LITTLE
 156 2ND STREET, SAN FRANCISCO, CA 94105
 T. 415-922-9900

LEGEND

26' WIDE AERIAL ACCESS
 WITHIN 15' TO 30'

AERIAL ACCESS NOTES

- STREET TREES WILL BE LOCATED ADJACENT TO THE AERIAL ACCESS ROADS WITH APPROXIMATELY 30' SPACING BETWEEN.

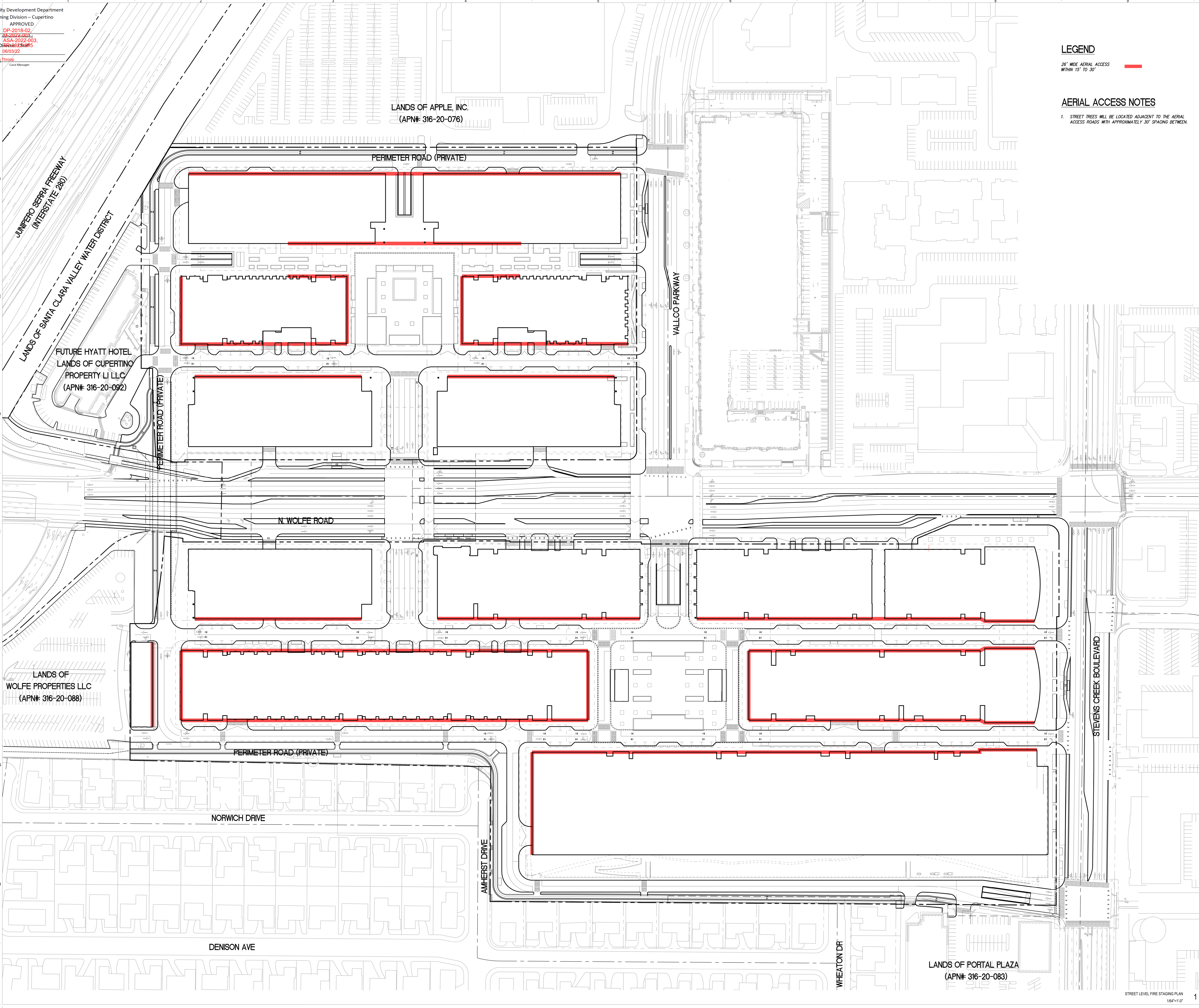

DATE MAY 27, 2022

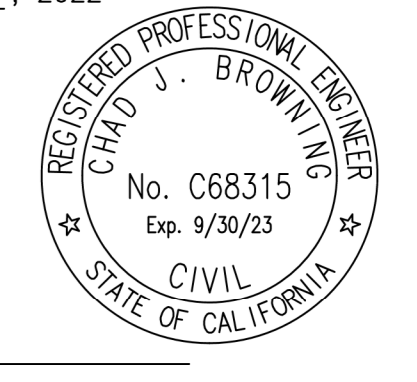

CHAD J. BROWNING
 R.C.E. NO. 68315, EXPIRES 9-30-23

NOT FOR CONSTRUCTION
 STAMP SIGNATURE

DISCLAIMER
 THE ARCHITECT/ENGINEER SHALL HAVE NO RESPONSIBILITY FOR ANY LIABILITY, LOSS, COST, DAMAGE OR EXPENSE ARISING FROM OR RELATING TO ANY USE OF THIS DOCUMENT FOR ANY PURPOSE OTHER THAN ITS INTENDED PURPOSE ON THIS PROJECT. THIS DOCUMENT IS TO BE CONSIDERED IN CONJUNCTION WITH ALL RELATED DOCUMENTATION. ANY DISCREPANCIES IDENTIFIED IN THIS DOCUMENT MUST BE REPORTED IMMEDIATELY TO THE ARCHITECT BEFORE PROCEEDING. CONTRACTORS MUST VERIFY ALL DIMENSIONS PRIOR TO PROCEEDING WITH ANY WORK. ONLY FIGURED DIMENSIONS ARE TO BE USED FOR VERIFICATION.

SB-35 MODIFICATION APPLICATION

REV	DESCRIPTION	DATE
REV-0	SB-35 DEVELOPMENT APPLICATION	03/27/2018
REV-1	SB-35 APPLICATION - REVISIONS	08/06/2018
REV-2	SB-35 APPLICATION CONFORM SET	09/15/2018
REV-3	SB-35 MODIFICATION APPLICATION	03/23/2022
REV-4	SB-35 MODIFICATION APPLICATION	05/27/2022

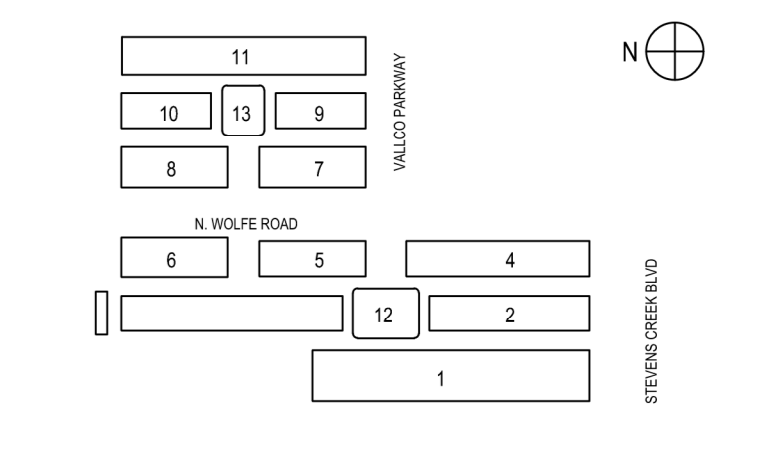

KEY PLAN AND NORTH ARROW
 ARCHITECTS PROJECT NUMBER 708.012

IF THIS DRAWING IS NOT 36"x48" IT IS A REDUCED PRINT:
 REFER TO GRAPHIC SCALE



FIRE STAGING PLAN - STREET LEVEL

SHEET TITLE
P-0409
 STREET LEVEL FIRE STAGING PLAN
 156"x11'0"

LANDS OF PORTAL PLAZA
 (APN# 316-20-083)