

OWNER - VALCO PROPERTY OWNER LLC
 2600 EL CAMINO REAL, SUITE 410, PALO ALTO, CA 94306
 T. 650-344-1500
 ARCHITECTURE - RAFAEL VINOLY ARCHITECTS
 315 PEARL STREET, 31ST FLOOR, NEW YORK, NY 10038
 T. 212-924-0600
 ARCHITECTURE - RAFAEL VINOLY ARCHITECTS
 10123 N. WOLFE ROAD, CUPERTINO, CA 95014
 T. 408-627-7090
 LANDSCAPE ARCHITECTURE - OLIN PARTNERSHIP LTD.
 1917 JOHN F. KENNEDY BLVD, SUITE 100, PHILADELPHIA, PA 19103
 T. 214-440-0030
 CIVIL - SANDS CIVIL ENGINEERS SURVEYORS PLANNERS, INC.
 1700 S. WINCHESTER BLVD, SUITE 200, CHAPPELL, CA 95008
 T. 408-638-0900
 TRAFFIC - KIMLEY-HORN AND ASSOCIATES, INC.
 1001 W. SAN FERNANDO STREET, SUITE 200, SAN JOSE, CA 95113
 T. 669-800-4130
 LIGHTING DESIGN - ONE LUX STUDIO
 196 WEST 29TH STREET, 10TH FLOOR, NEW YORK, NY 10001
 T. 212-201-5790
 SIGNAGE & WAYFINDING - EXIT DESIGN
 725 N. 4TH STREET, PHILADELPHIA, PA 19123
 T. 215-501-1950
 PARKING ENGINEERING - WATRY DESIGN, INC.
 2099 GATEWAY PLACE, SUITE 550, SAN JOSE, CA 95110
 T. 408-362-7000
 FOOD SERVICE, WASTE MANAGEMENT & LOGISTICS - CMI LITTLE
 156 2ND STREET, SAN FRANCISCO, CA 94105
 T. 415-922-9900

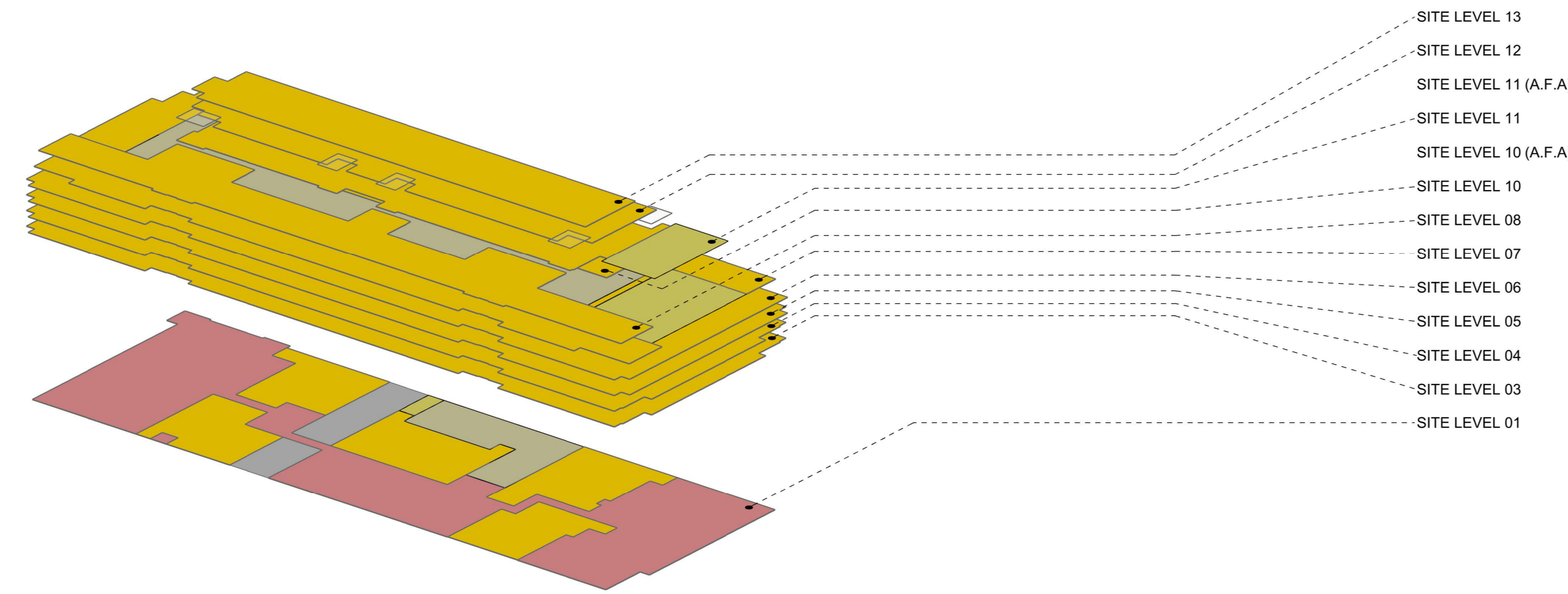

BLOCK 05	RESIDENTIAL			TOTAL RESIDENTIAL AREA	TOTAL OFFICE AREA	TOTAL RETAIL AREA	TOTAL FLOOR AREA
	UNIT AREA*	AMENITY AREA	PARKING AREA				
SITE LEVEL 25							
SITE LEVEL 24							
SITE LEVEL 23							
SITE LEVEL 22							
SITE LEVEL 15 - 21							
SITE LEVEL 14							
SITE LEVEL 13	14,301 SF			14,301 SF			14,301 SF
SITE LEVEL 12	21,326 SF			21,326 SF			21,326 SF
SITE LEVEL 11 (ADDITIONAL FLOOR AREA ABOVE 15 FT)**	1,253 SF			1,253 SF			1,253 SF
SITE LEVEL 11	25,820 SF	2,791 SF		28,611 SF			28,611 SF
SITE LEVEL 10 (ADDITIONAL FLOOR AREA ABOVE 15 FT)**	1,110 SF			1,110 SF			1,110 SF
SITE LEVEL 10	17,968 SF	443 SF		18,411 SF			18,411 SF
SITE LEVEL 09							
SITE LEVEL 08	18,690 SF			18,690 SF			18,690 SF
SITE LEVEL 07	31,319 SF	4,782 SF	31,774 SF	67,875 SF			67,875 SF
SITE LEVEL 06	37,087 SF		35,150 SF	72,237 SF			72,237 SF
SITE LEVEL 05	37,393 SF		35,150 SF	72,543 SF			72,543 SF
SITE LEVEL 04	37,393 SF		35,150 SF	72,543 SF			72,543 SF
SITE LEVEL 03	37,203 SF		35,150 SF	72,353 SF			72,353 SF
SITE LEVEL 02							
SITE LEVEL 01	23,403 SF	316 SF	6,289 SF	30,008 SF	36,447 SF		66,455 SF
TOTAL BLOCK AREA	304,265 SF	8,332 SF	178,863 SF	491,260 SF	36,447 SF		527,707 SF

NOTE:
 *BASE OF STAIRWELLS, BASE OF ELEVATOR SHAFTS, SERVICES AND MECHANICAL EQUIPMENT ROOMS ARE INCLUDED IN THE FLOOR AREA.
 **BASEMENTS WITH LIGHTWELLS THAT CONFORM TO SECTION 19.28.070(i) IS NOT INCLUDED IN THE FLOOR AREA.
 ***EXCLUDED AREAS SUCH AS PARKING FACILITIES OTHER THAN RESIDENTIAL GARAGES (PARKING RAMPS TO BASEMENT, DRIVE AISLES), LOADING, TRASH CENTER.

BLOCK 5
 N.T.S. 1

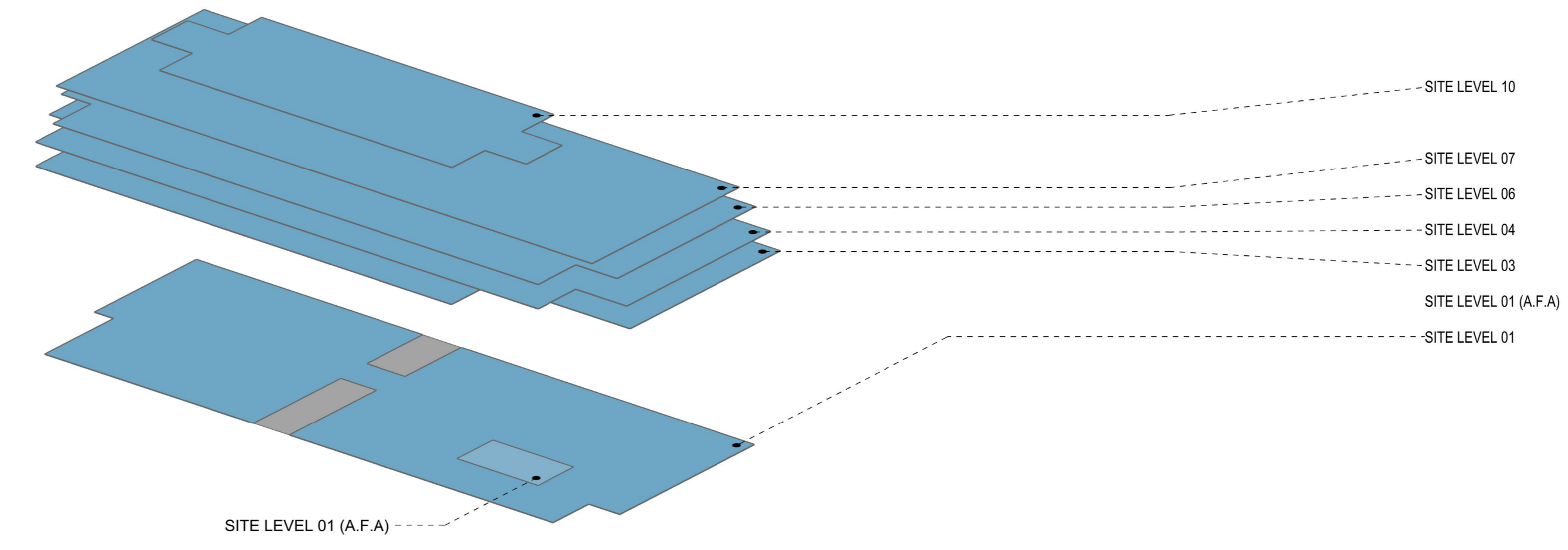

BLOCK 06	RESIDENTIAL			TOTAL RESIDENTIAL AREA	TOTAL OFFICE AREA	TOTAL RETAIL AREA	TOTAL FLOOR AREA
	UNIT AREA*	AMENITY AREA	PARKING AREA				
SITE LEVEL 25							
SITE LEVEL 24							
SITE LEVEL 23							
SITE LEVEL 22							
SITE LEVEL 15 - 21							
SITE LEVEL 14							
SITE LEVEL 13							
SITE LEVEL 12							
SITE LEVEL 11							
SITE LEVEL 10					20,437 SF		20,437 SF
SITE LEVEL 09							
SITE LEVEL 08							
SITE LEVEL 07					49,580 SF		49,580 SF
SITE LEVEL 06					61,072 SF		61,072 SF
SITE LEVEL 05							
SITE LEVEL 04					65,596 SF		65,596 SF
SITE LEVEL 03					66,768 SF		66,768 SF
SITE LEVEL 02							
SITE LEVEL 01 (ADDITIONAL FLOOR AREA ABOVE 20 FT)**					1,950 SF		1,950 SF
SITE LEVEL 01					57,920 SF		57,920 SF
TOTAL BLOCK AREA					323,323 SF		323,323 SF

NOTE:
 *BASE OF STAIRWELLS, BASE OF ELEVATOR SHAFTS, SERVICES AND MECHANICAL EQUIPMENT ROOMS ARE INCLUDED IN THE FLOOR AREA.
 **BASEMENTS WITH LIGHTWELLS THAT CONFORM TO SECTION 19.28.070(i) IS NOT INCLUDED IN THE FLOOR AREA.
 ***EXCLUDED AREAS SUCH AS PARKING FACILITIES OTHER THAN RESIDENTIAL GARAGES (PARKING RAMPS TO BASEMENT, DRIVE AISLES), LOADING, TRASH CENTER.

BLOCK 6
 N.T.S. 2

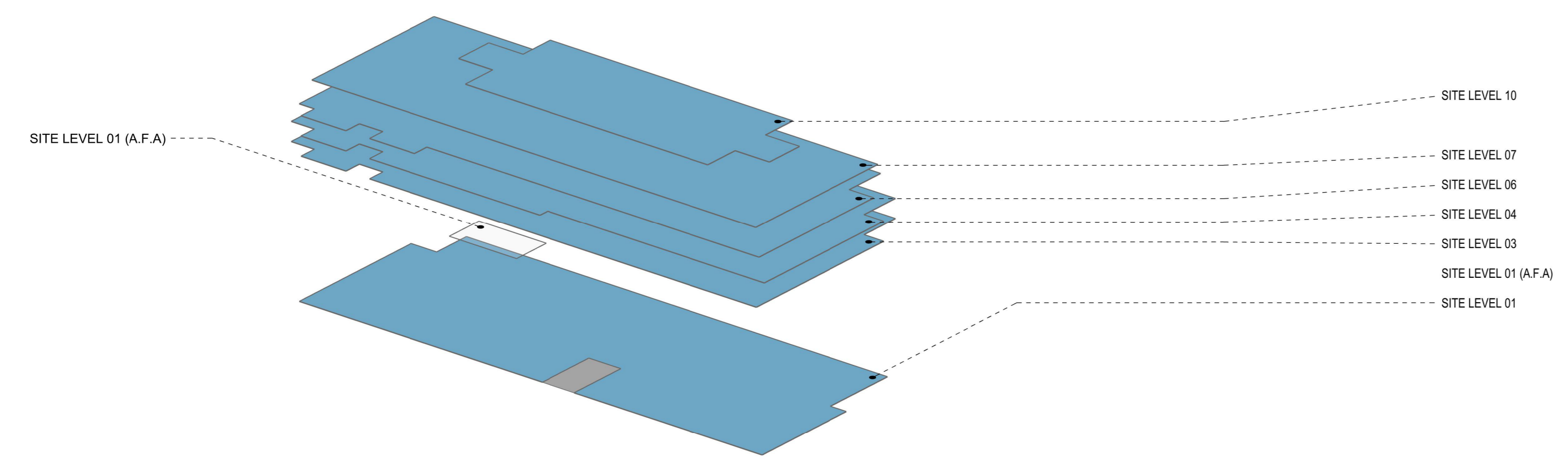

BLOCK 07	RESIDENTIAL			TOTAL RESIDENTIAL AREA	TOTAL OFFICE AREA	TOTAL RETAIL AREA	TOTAL FLOOR AREA
	UNIT AREA*	AMENITY AREA	PARKING AREA				
SITE LEVEL 25							
SITE LEVEL 24							
SITE LEVEL 23							
SITE LEVEL 22							
SITE LEVEL 15 - 21							
SITE LEVEL 14							
SITE LEVEL 13							
SITE LEVEL 12							
SITE LEVEL 11							
SITE LEVEL 10					20,437 SF		20,437 SF
SITE LEVEL 09							
SITE LEVEL 08							
SITE LEVEL 07					49,580 SF		49,580 SF
SITE LEVEL 06					62,118 SF		62,118 SF
SITE LEVEL 05							
SITE LEVEL 04					66,988 SF		66,988 SF
SITE LEVEL 03					66,164 SF		66,164 SF
SITE LEVEL 02							
SITE LEVEL 01 (ADDITIONAL FLOOR AREA ABOVE 20 FT)**					1,950 SF		1,950 SF
SITE LEVEL 01					59,973 SF		59,973 SF
TOTAL BLOCK AREA					327,210 SF		327,210 SF

NOTE:
 *BASE OF STAIRWELLS, BASE OF ELEVATOR SHAFTS, SERVICES AND MECHANICAL EQUIPMENT ROOMS ARE INCLUDED IN THE FLOOR AREA.
 **BASEMENTS WITH LIGHTWELLS THAT CONFORM TO SECTION 19.28.070(i) IS NOT INCLUDED IN THE FLOOR AREA.
 ***EXCLUDED AREAS SUCH AS PARKING FACILITIES OTHER THAN RESIDENTIAL GARAGES (PARKING RAMPS TO BASEMENT, DRIVE AISLES), LOADING, TRASH CENTER.

BLOCK 7
 N.T.S. 3

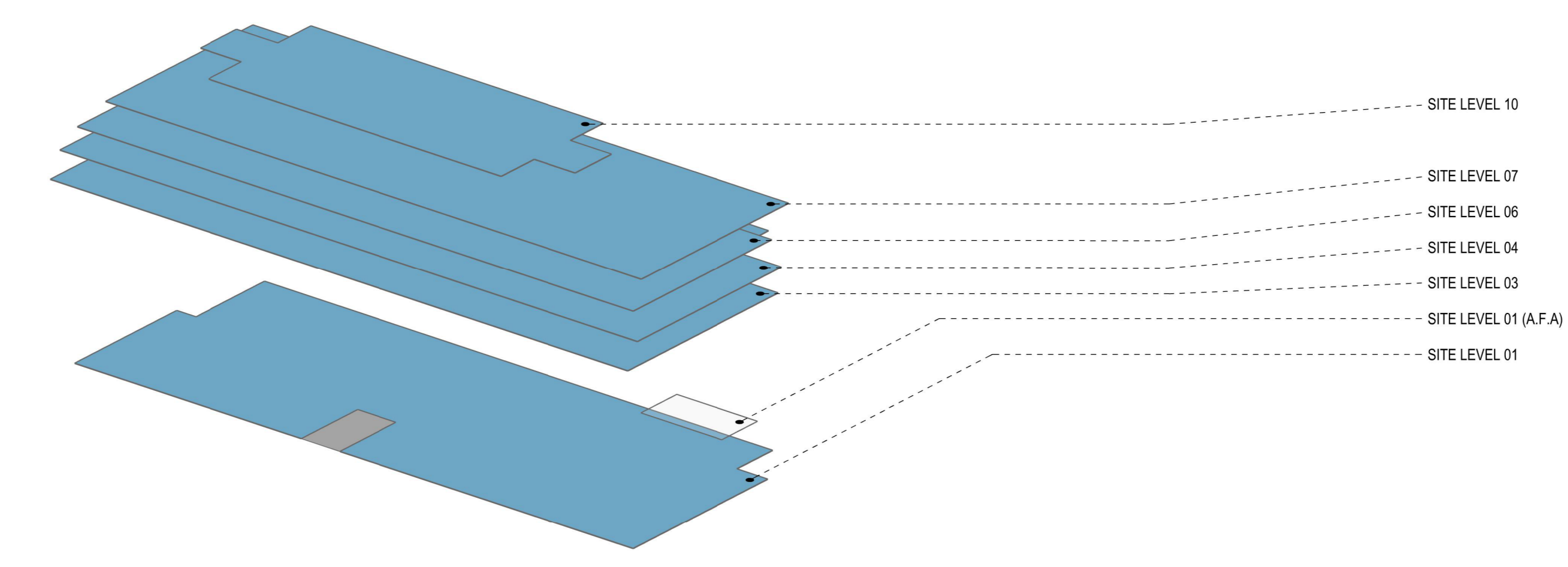

BLOCK 08	RESIDENTIAL			TOTAL RESIDENTIAL AREA	TOTAL OFFICE AREA	TOTAL RETAIL AREA	TOTAL FLOOR AREA
	UNIT AREA*	AMENITY AREA	PARKING AREA				
SITE LEVEL 25							
SITE LEVEL 24							
SITE LEVEL 23							
SITE LEVEL 22							
SITE LEVEL 15 - 21							
SITE LEVEL 14							
SITE LEVEL 13							
SITE LEVEL 12							
SITE LEVEL 11							
SITE LEVEL 10					20,438 SF		20,438 SF
SITE LEVEL 09							
SITE LEVEL 08							
SITE LEVEL 07					49,581 SF		49,581 SF
SITE LEVEL 06					61,072 SF		61,072 SF
SITE LEVEL 05							
SITE LEVEL 04					65,596 SF		65,596 SF
SITE LEVEL 03					66,765 SF		66,765 SF
SITE LEVEL 02							
SITE LEVEL 01 (ADDITIONAL FLOOR AREA ABOVE 20 FT)**					1,950 SF		1,950 SF
SITE LEVEL 01					59,973 SF		59,973 SF
TOTAL BLOCK AREA					325,375 SF		325,375 SF

NOTE:
 *BASE OF STAIRWELLS, BASE OF ELEVATOR SHAFTS, SERVICES AND MECHANICAL EQUIPMENT ROOMS ARE INCLUDED IN THE FLOOR AREA.
 **BASEMENTS WITH LIGHTWELLS THAT CONFORM TO SECTION 19.28.070(i) IS NOT INCLUDED IN THE FLOOR AREA.
 ***EXCLUDED AREAS SUCH AS PARKING FACILITIES OTHER THAN RESIDENTIAL GARAGES (PARKING RAMPS TO BASEMENT, DRIVE AISLES), LOADING, TRASH CENTER.

BLOCK 8
 N.T.S. 4

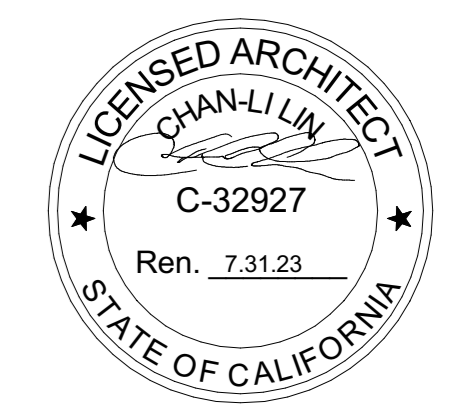

NOT FOR CONSTRUCTION
 STAMP / SIGNATURE
 DISCLAIMER
 THE ARCHITECT / ENGINEER SHALL HAVE NO RESPONSIBILITY FOR ANY LIABILITY, LOSS, COST, DAMAGE OR EXPENSE ARISING FROM OR RELATING TO ANY USE OF THIS DOCUMENT FOR ANY PURPOSE OTHER THAN ITS INTENDED PURPOSE ON THIS PROJECT. THIS DOCUMENT IS TO BE CONSIDERED IN CONJUNCTION WITH ALL RELATED DOCUMENTATION. ANY DISCREPANCIES IDENTIFIED IN THIS DOCUMENT MUST BE REPORTED IMMEDIATELY TO THE ARCHITECT BEFORE PROCEEDING. CONTRACTORS MUST VERIFY ALL DIMENSIONS PRIOR TO PROCEEDING WITH ANY WORK. ONLY FOURED DIMENSIONS ARE TO BE USED FOR VERIFICATION.

SB-35 MODIFICATION APPLICATION

REV	DESCRIPTION	DATE
REV-0	SB-35 APPLICATION - REVISION	08/06/2018
REV-1	SB-35 APPLICATION - CONFORM SET	09/15/2018
REV-2	SB-35 MODIFICATION APPLICATION	03/23/2022

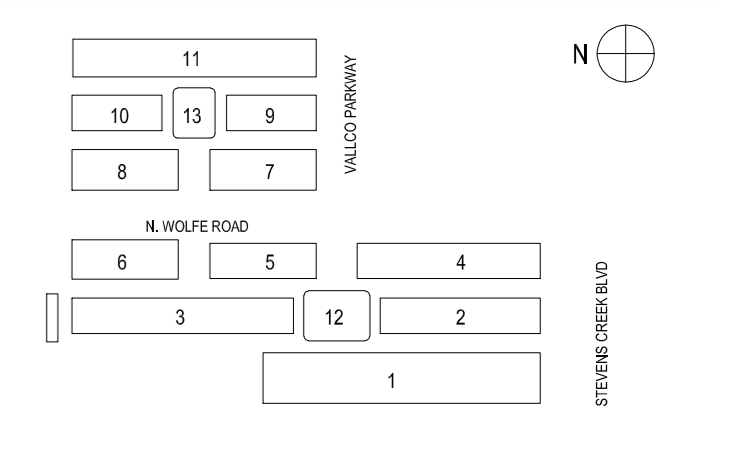

ARCHITECTS PROJECT NUMBER: 708.012

IF THIS DRAWING IS NOT 36"X48" IT IS A REDUCED PRINT. REFER TO GRAPHIC SCALE.

SCALE: AS NOTED

AREA CALCULATION :
PER BLOCK AND LEVEL
(BLOCK 5 TO BLOCK 7)

SHEET TITLE:
P-0107
 SHEET NUMBER:
 © 2022 RAFAEL VINOLY ARCHITECTS PCL