

OWNER - VALCO PROPERTY OWNER LLC
2800 EL CAMINO REAL, SUITE 410, PALO ALTO, CA 94306
T. 650-344-1500

ARCHITECTURE - RAFAEL VINOLY ARCHITECTS
375 PEARL STREET, 31ST FLOOR, NEW YORK, NY 10038
T. 212-924-9500

ARCHITECTURE - RAFAEL VINOLY ARCHITECTS
10123 N. WOLFE ROAD, CLIFPERTON, CA 95014
T. 408-627-7090

LANDSCAPE ARCHITECTURE - OLAN PARTNERSHIP LTD.
1811 JOHN F. KENNEDY BLVD. SUITE 1900, PHILADELPHIA, PA 19103
T. 214-440-0030

CIVIL - SANDS CIVIL ENGINEERS SURVEYORS PLANNERS, INC.
1100 S. WINCHESTER BLVD., SUITE 200, CAMPSBELL, CA 95008
T. 408-638-9000

TRAFFIC - KIMLEY HORN AND ASSOCIATES, INC.
1910 W. SAN FERNANDO STREET, SUITE 250, SAN JOSE, CA 95113
T. 650-350-7000

LIGHTING DESIGN - ONE LUX STUDIO
158 WEST 20TH STREET, 10TH FLOOR, NEW YORK, NY 10011
T. 212-201-6790

SIGNAGE & WAYFINDING - EXIT DESIGN
725 N. 4TH STREET, PHILADELPHIA, PA 19123
T. 215-681-1900

PARKING ENGINEERING - WATRY DESIGN, INC.
2099 GATEWAY PLACE, SUITE 550, SAN JOSE, CA 95110
T. 408-350-7000

FOOD SERVICE, WASTE MANAGEMENT & LOGISTICS - CNU-LITTLE
156 2ND STREET, SAN FRANCISCO, CA 94105
T. 415-522-5900

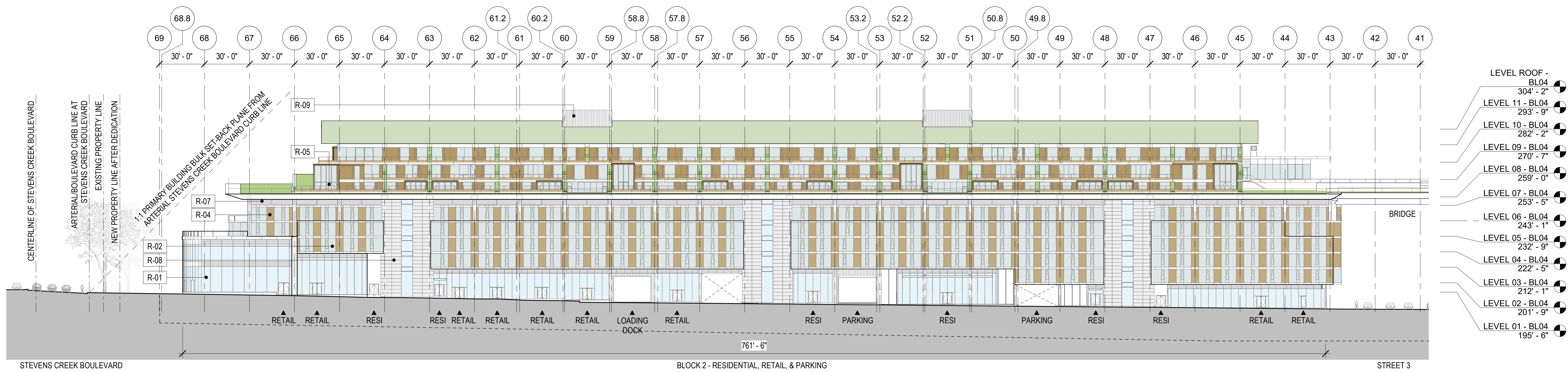

BLOCK 4 - BUILDING ELEVATION
1/32" = 1'-0"

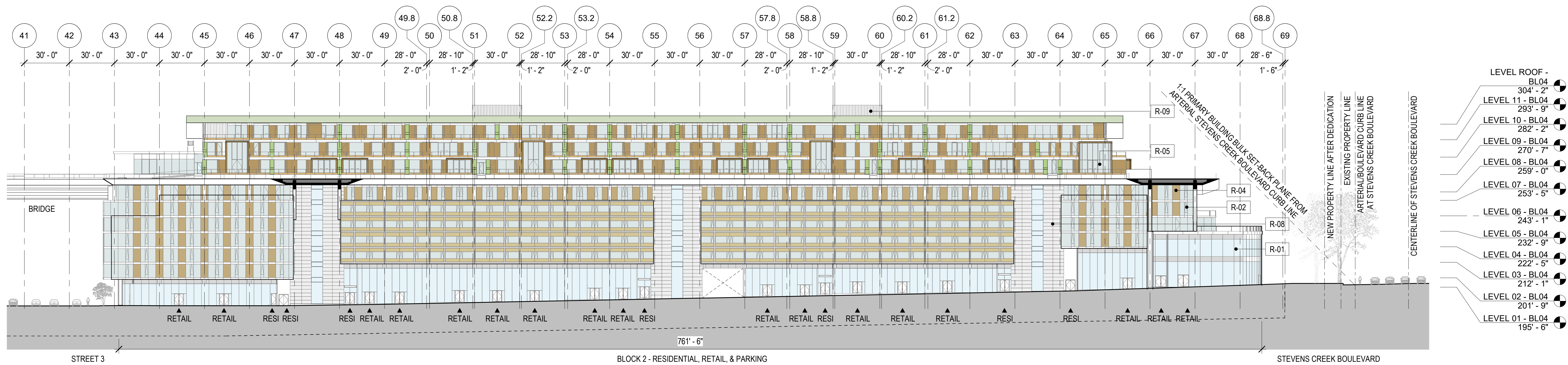

BLOCK 4 - BUILDING ELEVATION
1/32" = 1'-0"

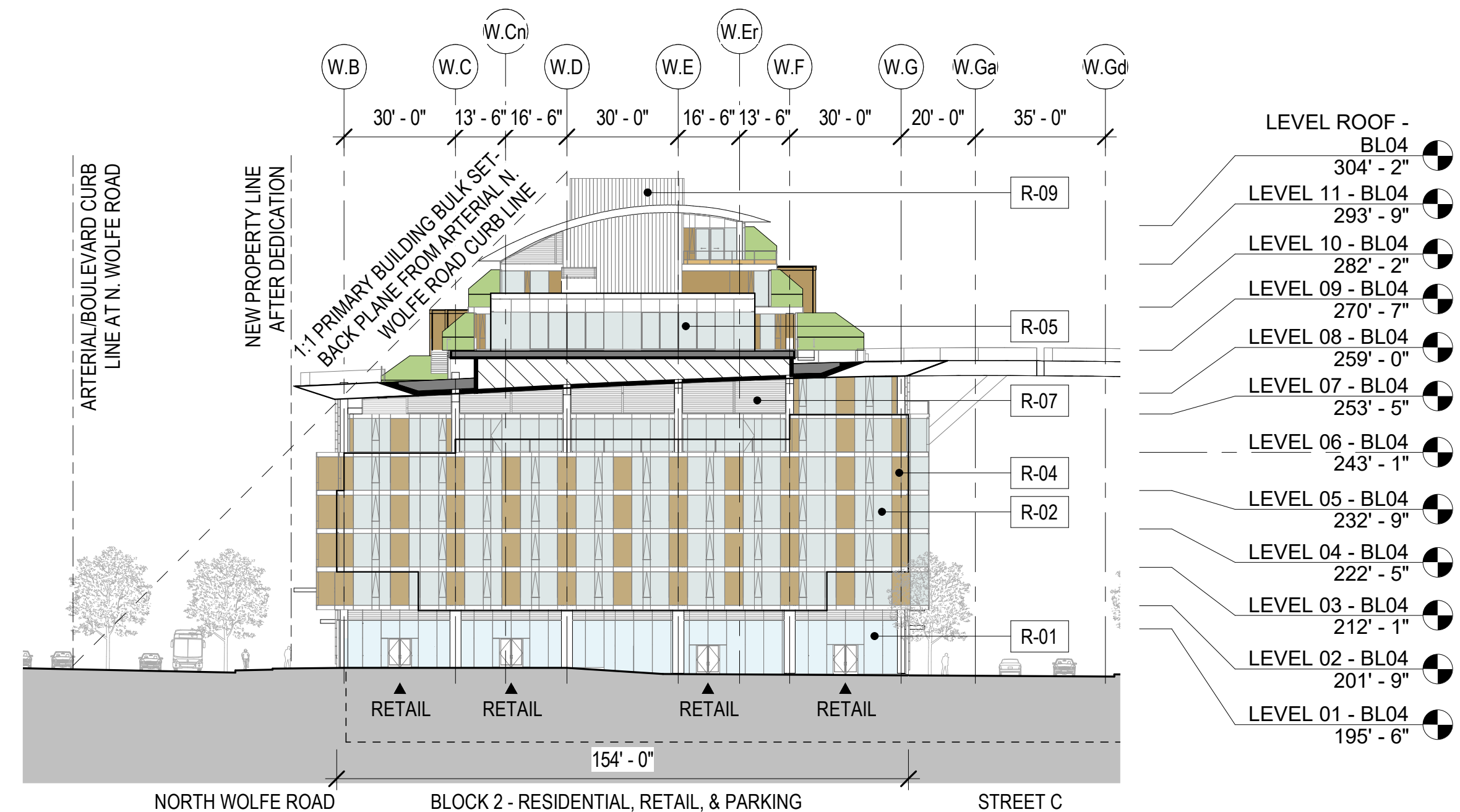

WALL FINISH LEGEND - OFFICE BLOCKS

O-01 STOREFRONT

O-02 TRANSPARENT PANEL

O-03 OPAQUE PANEL

O-04 ARCHITECTURAL LOUVERS (MEP SCREENING)

REFER TO P-0862 FOR FURTHER INFORMATION

WALL FINISH LEGEND - RESIDENTIAL BLOCKS

R-01 STOREFRONT

R-02 TRANSPARENT PANEL

R-03 SLIDING SCREENS

R-04 "WOOD" LOOK OPAQUE PANEL

R-05 SLIDING, SWING, AND FOLDING DOORS

R-06 WINDOW WALL

R-07 ARCHITECTURAL LOUVERS (MEP SCREENING)

R-08 STONE CLADDING

R-09 METAL PANEL CLADDING

REFER TO P-0861 FOR FURTHER INFORMATION

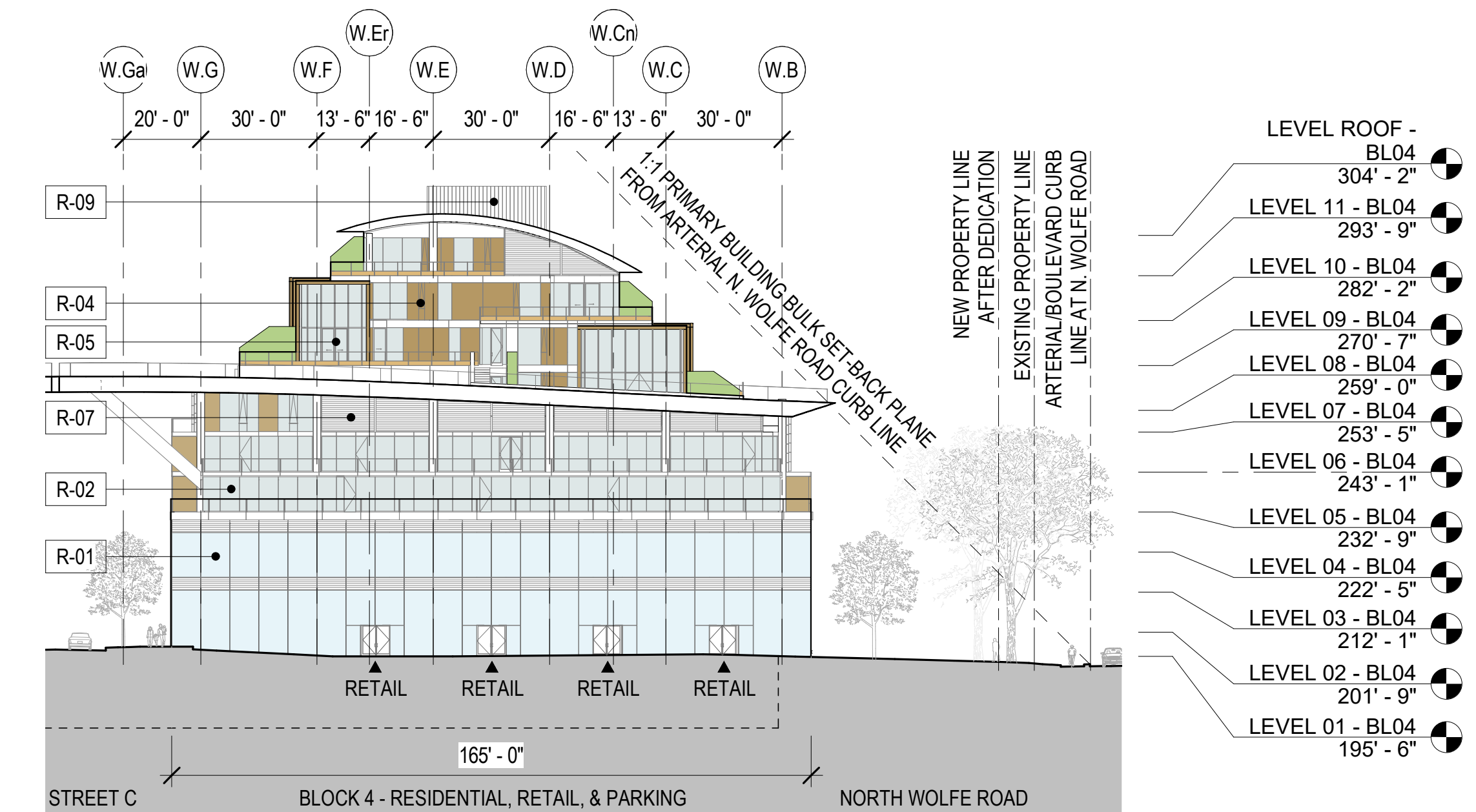

BLOCK 4 - BUILDING ELEVATION
1/32" = 1'-0"

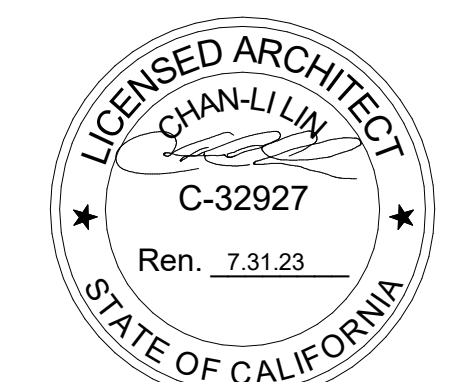

NOT FOR CONSTRUCTION

STAMP / SIGNATURE

DISCLAIMER
THE ARCHITECT / ENGINEER SHALL HAVE NO RESPONSIBILITY FOR ANY LIABILITY, LOSS, COST, DAMAGE OR EXPENSE ARISING FROM OR RELATING TO ANY USE OF THIS DOCUMENT FOR ANY PURPOSE OTHER THAN ITS INTENDED PURPOSE ON THIS PROJECT. THIS DOCUMENT IS TO BE CONSIDERED IN CONJUNCTION WITH ALL RELATED DOCUMENTATION. ANY DISCREPANCIES IDENTIFIED IN THIS DOCUMENT MUST BE REPORTED IMMEDIATELY TO THE ARCHITECT BEFORE PROCEEDING. CONTRACTORS MUST VERIFY ALL DIMENSIONS PRIOR TO PROCEEDING WITH ANY WORK. ONLY FIGURED DIMENSIONS ARE TO BE USED FOR VERIFICATION.

SB-35 MODIFICATION APPLICATION

REV	DESCRIPTION	DATE
REV-0	SB-35 APPLICATION - REVISION	08/06/2018
REV-1	SB-35 APPLICATION - CONFORM SET	09/15/2018
REV-2	SB-35 MODIFICATION APPLICATION	02/23/2022

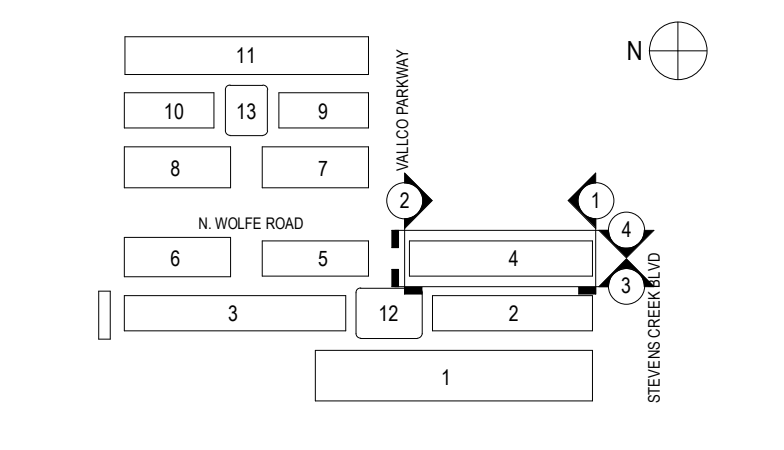

KEY PLAN AND NORTH ARROW

ARCHITECTS PROJECT NUMBER 708.012

IF THIS DRAWING IS NOT 36"x48" IT IS A REDUCED PRINT. REFER TO GRAPHIC SCALE.

SCALE: AS NOTED

ENLARGED BUILDING ELEVATIONS - BLOCK 4

SHEET TITLE
P-0825.04

SHEET NUMBER